

SKINTOP® MS-NPT BRUSH

SKINTOP® MS-NPT BRUSH,

, NPT

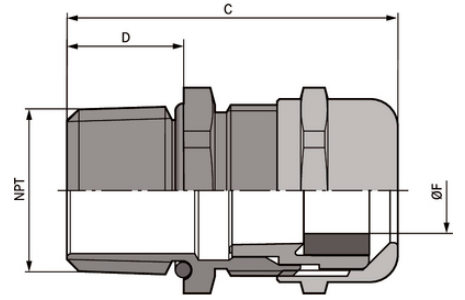

360°

가

EMC

UL

E79903

(20.08.2024)



SKINTOP® MS-NPT BRUSH

ASME B1.20.1 - 2013

NPT

ETIM 5:

ETIM 5.0 Class-ID: EC000441

ETIM 5.0 :

ETIM 6:

ETIM 6.0 Class-ID: EC000441

ETIM 6.0 Class :

:

:

:

:

EMC brush :

UL 94

:

O :

가:

IP 68 - 10 bar

NEMA Type 1, 4x, 6, 12

:

Dynamic: -25°C up to +100°C

: -40°C ~ +100°C

가 VAT

가 가 .

(20.08.2024)

©2024 Lapp Group - all rights reserved.

<http://lappkorea.lappgroup.com>

data sheet

PN 0456 / 02_03.16



SKINTOP® MS-NPT BRUSH

	Article designation / size	Ø F mm	SW (mm)	, C mm	Thread length D mm	/ PU
SKINTOP® MS-NPT BRUSH						
53112037	NPT 3/4"	9 - 17	29	43.0	15	10
53112047	NPT 1"	11 - 21	36	48.2	15	1
53112057	NPT 1 1/4"	19 - 28	45	57.5	17	1
53112067	NPT 1 1/2"	27 - 35	54	59.0	17	1
53112077	NPT 2"	34 - 45	67	63.3	17	1
53112087	NPT 2" plus	44 - 55	75	72.5	17	1

(20.08.2024)

©2024 Lapp Group - all rights reserved.

<http://lappkorea.lappgroup.com>

data sheet

PN 0456 / 02_03.16